

Cardio Theater xTV-8T Transmitter

Installation and Maintenance Guide

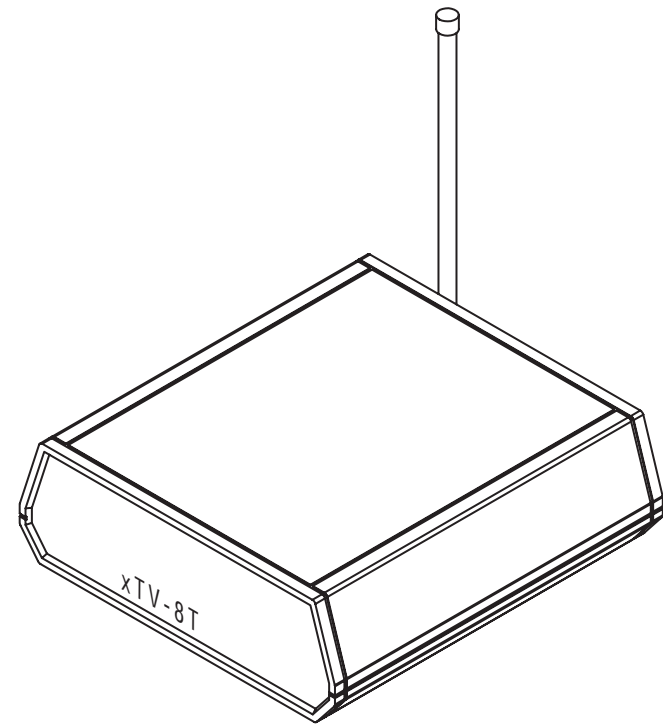

CARDIO  THEATER®

Important Safety Guidelines

Always follow basic safety precautions when using this equipment to reduce the chance of injury, fire, or damage.

- Read all precautions in this guide before installing and using the equipment. Follow any labels on the equipment.
- Use the power adapter provided with the equipment. Plug the power adapter into an appropriate, grounded power outlet as marked on the equipment.
- Route power cords so that they are not walked on or pinched by items placed upon or against them.
- Ensure that the equipment has adequate ventilation. Do not place anything on top of or over the equipment. Do not use on a cushioned surface that could block the ventilation openings.
- Keep the equipment away from water and moisture.
- Locate the equipment away from sources of heat, such as radiators, heat registers, and stoves. Avoid temperature extremes.
- Avoid dropping anything on or spilling anything inside the equipment, because doing so can damage the electronics.

Regulatory Information

This product is compliant to:

- 89/336/EEC Electromagnetic Compatibility Directive.
- 99/5/EEC Radio and Telecommunications Directive.
- 73/23/EEC Low Voltage Directive.

Table of Contents

Important Safety Guidelines	1	Installing the Transmitter	6
Regulatory Information	1	Maintaining and Troubleshooting	9
Before You Begin	3	Cleaning the Transmitter	9
Obtaining Service	3	Troubleshooting the Transmitter	9
Preparations	4	Limited Warranty	12
Unpacking the Equipment	4		
Required Tools	4		
Installation Requirements	4		

Before You Begin

With the Cardio Theater® xTV wireless system, fitness facilities can add entertainment to exercise rooms without the high cabling costs usually associated with entertainment systems. The xTV wireless system gives people the choice of listening to music, radio, or programs shown on TVs while they exercise. The person simply plugs a stereo headphone into a receiver, selects the desired entertainment, and exercises while listening to high-fidelity sound.

An xTV wireless system consists of one or more xTV-8T Transmitters, one for each TV and audio component, and a number of xTV-8R Receivers installed on exercise equipment throughout the room. Because the xTV-8T Transmitter supports 12 different frequencies, facilities can install up to 12 transmitters to support a wide variety of entertainment options.

This guide explains how to install and maintain an xTV-8T Transmitter. For proper installation, please read this guide thoroughly and follow the instructions.

Note: For information about the xTV-8R Receivers, refer to the *xTV-8R Receiver Installation and Maintenance Guide*.

Obtaining Service

Do not attempt to service the xTV-8T Transmitter except as described in this guide. For information about product operation or service, refer to the Cardio Theater web site at www.cardiotheater.com or contact an authorised dealer. For information about product operation or service, contact an authorised Cardio Theater Technical Support Representative at +44 118 973 9633 or emeaservice@cardiotheater.com.

Returning Equipment to Cardio Theater

To return equipment to Cardio Theater for any reason, you must contact Cardio Theater Technical Support and obtain a Return Authorisation Number (RMA). When requesting the RMA number, explain why you are returning the equipment, for example you ordered too many receivers and the extra receiver can be returned to stock, or the equipment needs repairs.

Important: *Equipment must be shipped with an RMA number in order for Cardio Theater to process it. Any equipment received without an RMA number will be returned to the sender.*

Preparations

Remember to read and follow the instructions in this guide. If you do not install the xTV-8T Transmitter according to these instructions, you could void the Limited Warranty.

Unpacking the Equipment

The transmitter is shipped with the following items:

- One or more xTV-8T Transmitters as ordered

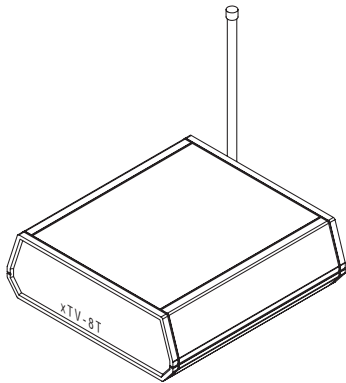

- AC adapter for your country, 1 per transmitter
- RCA audio cable, 1 per transmitter
- Numbered signs to post near TVs and audio components
- These installation instructions

If any items are missing, contact the dealer from whom you purchased the equipment or contact Cardio Theater Technical Support.

Required Tools

Obtain the following before installation:

- Small flathead screw driver

Installation Requirements

Review the following installation requirements before assembly:

- You can install up to twelve transmitters, depending on the infrastructure and radio frequency activity in the area.
- To ensure the best range and audio quality possible for the transmitter(s), select a location for installing them without any major internal obstructions, such as metal support posts, between transmitters and receivers installed on the exercise equipment. Transmitters and receivers should also be installed so they are within 50 meters of each other and are in direct line of sight.
- Cardio Theater recommends that you group audio components together to minimize cabling. Also, install the transmitters and other audio components in a central location for better transmission coverage.
- If you are installing more than one transmitter, you must place them at least 30 cm apart. Do not stack transmitters on top of each other. If transmitters are placed too closely together, the facility may experience poor sound quality.
- If the audio components are stacked in a cabinet, make sure the equipment has adequate ventilation to avoid overheating.

- Place the antenna on the transmitter so it is vertical. In addition, the antenna should not touch or come near other transmitting antennas or metal objects. Be sure to route cabling and power cables away from the antenna, so they do not cause interference.
- Each transmitter requires a unique channel number. Channel numbers on transmitters determine their frequencies. There is no correlation between channel numbers on transmitters and channel numbers shown on receivers when they are programmed.
- Before installing the xTV wireless system, you may want to check for possible conflicts with the frequencies using a radio frequency analyzer or frequency scanner. Certain wireless microphone systems available throughout Europe transmit between 863 and 865 MHz. If the facility uses this type of wireless microphone system, it may interfere with the Cardio Theater xTV wireless system. To solve the conflict, Cardio Theater recommends the facility change the wireless microphone system to a 173.8 to 175 VHF system.
- If you discover that some of the 800 MHz frequencies (see Table 1) are used by outside non-controllable sources, you can set the transmitter to avoid those frequencies. However, this will reduce the number of channels available for you to use when installing transmitters. If the outside non-controllable source generates a powerful signal, it may also cause static interference with the wireless system, reducing audio quality.
- With new xTV wireless installations, we recommend installing the receivers on the equipment first, then installing the transmitters. Doing so will allow installers to check the sound quality of the transmitters throughout the room.
- The receiver automatically acquires the available channels from the installed transmitters and assigns them to channel numbers, starting with the lowest transmitting channel to the highest transmitting channel, regardless of which channels are used. To avoid confusion with people using the wireless system, you want receivers to logically select TV and audio components based on their placement. So, on the receiver, channel 1 would select the first TV, channel 2 would select the second TV, and so on. To support this logical usage, transmitters need to be installed in channel order.
- Transmitters use Automatic Level Control (ALC) circuitry to provide consistent sound levels to people using the receivers. With this feature, once the sound level on TVs and other audio components have been adjusted, the wireless system should not experience sound fluctuations, which have been inherent in other types of entertainment systems. To support this feature, the sound level from the connected TV and audio components must be set to a reasonable, median level. If the incoming sound level is set too low, people may hear an excessive amount of background noise while using the receivers. If the incoming sound level is set too high, it may sound distorted through the receivers.

Installing the Transmitter

1. Determine where you will install each transmitter. If possible, locate the transmitters where their signals will have no obstructions (such as metal support posts) to the receivers installed on the exercise equipment. In addition, the distance between receivers and transmitters should not exceed 50 meters.
2. Determine the channel number you want to assign to each transmitter. Each transmitter requires a unique channel number. Transmitters should be installed in order of their channel number to make the wireless system easier to use. See Table 1.

Note: Table 1 provides blank columns that installing technicians can use to note setup information. Consider providing a brief description of what entertainment each transmitter provides (or is connected to) and indicate the associated receiver channel that gets assigned.

Table 1: Site with up to 12 transmitters

<i>Transmitter Channel</i>	<i>Transmitter Frequency</i>	<i>Description of Channel (Write a brief description for your site)</i>	<i>Receiver Channel</i>
1	863.050		
2	863.200		
3	863.400		
4	863.550		
5	863.750		
6	863.900		
7	864.100		
8	864.250		
9	864.450		
10	864.600		
11	864.800		
12	864.950		

3. Set the channel number on the transmitter by adjusting the two Channel Select dials on the back with a small flathead screw driver.

Figure 1 shows where to adjust the dials with the screw driver. Refer to Table 2 to determine how to adjust each dial to select a channel number, based on your country.

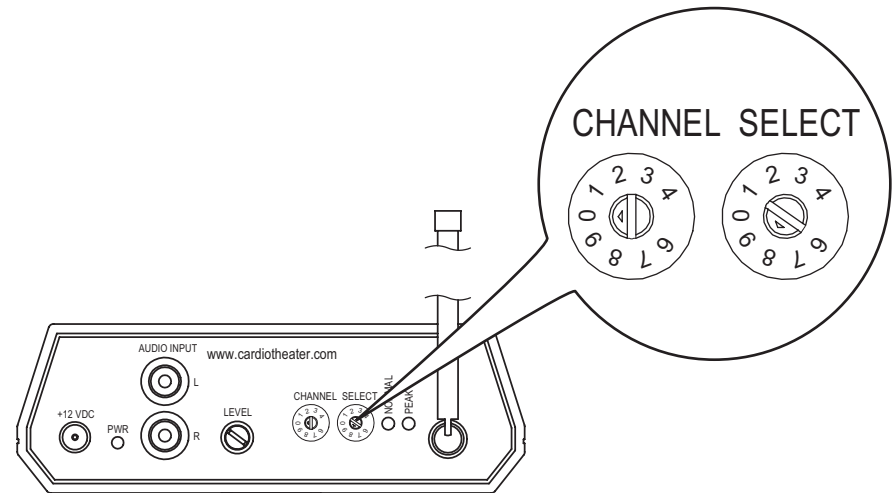

Figure 1: Set a unique channel number for each transmitter

Different channel numbers will provide better reception based on whether or not other equipment in the facility are using the same frequency, or possible influences from the facility infrastructure. During installation, you may need to change the channel number based on the quality of the sound captured by the receivers.

Table 2: Allowed channel numbers for EU countries

<i>Channel Number</i>	<i>Set Left Dial</i>	<i>Set Right Dial</i>
1	0	1
2	0	2
3	0	3
4	0	4
5	0	5
6	0	6
7	0	7
8	0	8
9	0	9
10	1	0
11	1	1
12	1	2

4. Place the transmitter where it will operate. Make sure that it is located in a well-ventilated area with both the front and back easily accessible.

You can place the transmitter on top of the TV or audio component it will be transmitting, or in a rack nearby.

Important: *If you are installing more than one transmitter, you must place them at least 30 cm apart. Do not stack transmitters on top of each other. If transmitters are placed too closely together, they may interfere with each other's signals.*

5. Adjust the antenna on the transmitter so that it is vertical.
6. Plug the power cord on the AC adapter, packaged with the transmitter, into the back.
Important: *Make sure the power cord is not near the antenna, or it could interfere with the audio signal.*
7. Plug the AC adapter into a nearby power outlet.
8. Connect one end of the RCA audio cable to the TV or audio source. Observe and follow the color code of the RCA audio cable connectors. If available, connect the RCA cable to the Line Audio Output connector on the TV or audio source.
The Line Audio Output connector is recommended because it always provides a consistent sound level and cannot be modified by users.
9. Connect the other end of the RCA audio cable to the transmitter. Observe and follow the color code of the RCA audio cable connectors.
Important: *Make sure the RCA cable is not near the power cable, or it could interfere with the audio signal.*
10. If connecting to a TV, turn off its speakers using the appropriate menu function.

11. If you connected the RCA audio cable to a variable audio output connector, set the sound level so it is at 25 to 50 percent.
12. Set the sound level so users receive a consistent sound level. You will need to look at the back of the transmitter to perform this step. See Figure 2.

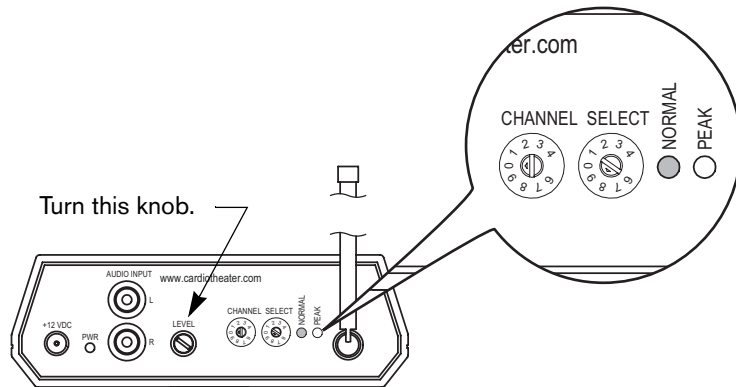

Figure 2: Watch the lights to adjust volume appropriately

- a. Turn the potentiometer Level knob clockwise, until the green Normal light is solid and the red Peak light flashes infrequently. The potentiometer Level knob is located on the back of the Transmitter.
 You have gone too far if the red Peak light is flashing frequently or glowing solidly. In this case, turn the potentiometer Level knob counterclockwise until the red Peak light flashes once in a while.
- b. Stop adjusting the volume and watch the lights. The transmitter will automatically correct its volume to level it out. When this process is done, the red Peak light flashes infrequently and the green Normal light remains solid.

13. When all the transmitters are installed, check the sound quality from the transmitters using the receivers at each piece of exercise equipment around the room.

If you find that a specific channel is not received well anywhere in the room, try changing the transmitter to a different channel. You may need to try several channels to improve sound quality. Some channels will be received better than others in a facility due to the infrastructure and radio frequency activity in the area. If you need to change the channel on a transmitter to improve sound quality, you will need to reprogram the receivers.

If you find that you cannot receive a specific channel at a piece of equipment, you may need to move the transmitter to another location to provide better coverage all over.

14. Make sure the sound levels provided by transmitters are consistent across all channels. Plug headphones into a wireless receiver, then move through the channels, listening to the sound level and checking for disturbing or noticeable differences as you switch channels. If necessary, match the sound level provided by each TV and audio component by making slight adjustments to that component's volume.
15. Place the appropriate numbered signs by each TV or audio component. People will use the number on each sign to select the desired entertainment.

Maintaining and Troubleshooting

In general, the xTV-8T Transmitter requires little maintenance. Refer to *Cleaning the Transmitter* for information.

Problems with the transmitter typically occur during installation. Otherwise, you should experience few problems once the transmitters are installed correctly. If needed, you may find the troubleshooting information in this section useful for solving any problems you experience.

Cleaning the Transmitter

Periodically dust the transmitter with a soft dry cloth.

Important: Do not use liquid cleaners or aerosol cleaners to clean the equipment. Do not use any solvents such as alcohol and paint thinner.

Troubleshooting the Transmitter

Table 3 may help you to understand and troubleshoot any problems that you encounter with the xTV-8T Transmitter. If the suggestions in the table do not help you solve the problems that you encounter, contact Cardio Theater Technical Support.

Table 3: How to solve most problems with transmitters

Problem		What to Do
Static interference	Single receiver	Most likely problem with receiver; see <i>Maintenance and Troubleshooting</i> in receiver guide.
	All receivers	Sound level on TV or audio component may be too high. Check the equipment and adjust the sound level as needed. Make sure the transmitter has power by checking the power cord on the AC Adapter: Is it plugged into a nearby outlet and into the transmitter? Make sure that the antenna is upright and not located near the power cord, audio cable, or any metal objects. Make sure the transmitter is set to the correct channel number. If necessary, change the channel number on the back. Check to see if any outside sources are using the same frequency as the transmitter. Either locate and remove the outside interference, or change the transmitter to a different channel to avoid that frequency. If the problem continues, unplug the power cord for five minutes, then plug back in.

Problem		What to Do
Noisy sound	Single receiver	<p>Make sure there are no major internal obstructions, such as metal support posts, between transmitter and receiver. If necessary, move the transmitter to another location for better coverage all over.</p> <p>Otherwise, most likely problem with receiver; see <i>Maintenance and Troubleshooting</i> in receiver guide.</p>
	All receivers	<p>Make sure the transmitter and receivers are installed so they are within 50 meters of each other.</p> <p>Make sure that the antenna is upright and not located near the power cord, audio cable, or any metal objects.</p> <p>Make sure the sound level of the TV or audio component connected to the transmitter is set to a reasonable, median level.</p> <p>Try changing the transmitter to a different channel to see if the sound quality improves. Some channels will be received better than others.</p> <p>Make sure no other transmitters are using the same channel (and frequency) at the facility. If other types of transmitters are installed, you should call Technical Support for help with determining the frequencies being used. If necessary, change the channel number on the errant transmitter.</p> <p>Check to see if any outside sources are using the same frequency as the transmitter. Either locate and remove the outside interference, or change the transmitter to a different channel to avoid that frequency.</p>

Problem		What to Do
No sound	Single receiver	<p>Make sure there are no major internal obstructions, such as metal support posts, between transmitter and receiver. If necessary, move the transmitter to another location for better coverage all over.</p> <p>Otherwise, most likely problem with receiver; see <i>Maintenance and Troubleshooting</i> in receiver guide.</p>
	All receivers	<p>Sound on the TV or audio component may be too low or muted. Check the equipment and increase the sound or unmute as needed.</p> <p>Make sure the transmitter has power by checking the power cord on the AC Adapter: Is it plugged into a nearby outlet and into the transmitter?</p> <p>Make sure the transmitter is set to the correct channel number. If necessary, change the channel number on the back.</p>
Receiver channels do not match the order of the TV and audio components; for example, channel 1 selects the second TV and channel 2 selects the first TV.		Transmitters were not installed in channel order. Receivers automatically assign transmitter channels to receiver channels, from lowest to highest (see Tables 4 and 5). Move or reprogram transmitters so channel numbers are in a logical sequence. You will need to reprogram receivers.

Understanding How Receivers Order Transmitter Channels

During automatic programming, the xTV-8R Receiver automatically searches the area for active transmitter channels and stores them in memory. For example, an installation has five xTV-8T Transmitters, assigned channel numbers 2, 6, 7, 10, and 11; they are installed in that order from left to right. The receiver has found these transmitted channels and assigned them to a sequence of channel numbers that it displays as 1 through 5. See Table 4.

Table 4: Sample installation with showing correct channel order

<i>Transmitter Channels (Installed in Channel Order)</i>	<i>Receiver Assigns to Channel Number that People Use to Select Entertainment</i>
1	
2	1
3	
4	
5	
6	2
7	3
8	
9	
10	4
11	5
12	

Sometimes an installation may have the transmitters installed where they are not installed in numeric order, from the lowest channel number to the highest channel number. For example, an installation could have the transmitters installed 2, 6, 4, 10, and 11. Table 5 shows what happens with the receiver in this situation. The receiver finds the transmitted channels and still assigns them in numeric order, from lowest to highest. A site with this situation would find that receiver channel 3 would select the second TV, and receiver channel 2 would select the third TV, causing confusion with people using the system. The solution would be to switch transmitters, so the second TV would have the transmitter set to channel 4, and the third TV would have the transmitter set to channel 6.

Table 5: Example with transmitters out of order

<i>Transmitter Channels as Installed</i>	<i>Receiver Assigns to Number that People Use to Select Component</i>
1	
2	1
3	
6	3
4	2
5	
7	
8	
9	
10	4
11	5
12	

Limited Warranty

PLEASE READ THESE WARRANTY TERMS AND CONDITIONS CAREFULLY BEFORE USING YOUR CARDIO THEATER PRODUCT. BY USING THE EQUIPMENT, YOU ARE CONSENTING TO BE BOUND BY THE FOLLOWING WARRANTY TERMS AND CONDITIONS.

Limited Warranty.

Precor Incorporated ("Precor") warrants all new Cardio Theater products to be free from defects in materials and manufacture for the warranty periods set forth below. The warranty periods commence on the invoice date of the original purchase. This warranty applies only against defects discovered within the warranty period and extends only to the original purchaser of the product. Parts repaired or replaced under the terms of this warranty will be warranted for the remainder of the original warranty period only. To claim under this warranty, the buyer must notify Precor or your authorized Cardio Theater dealer within 30 days after the date of discovery of any nonconformity and make the affected product available for inspection by Precor or its service representative. Cardio Theater product deemed defective by a Cardio Theater representative, will be issued a return authorization number. **Precor will not accept returns without a return authorization number.** Precor reserves the right, at their option, to repair or replace the product after verification of defect. Product that fails after the warranty period expires will be repaired or replaced at the current part and labor pricing after authorization from the customer. Repairs are warranted for 90 days.

Precor's obligations under this warranty are limited as set forth below.

Warranty Periods and Coverage.

• Cardio Theater Transmitters <i>xTV-T Wireless or Wired Floor Models xTVFM system transmitter</i>	3 Years	Parts & Labor
• Cardio Theater Receivers <i>XTV-R Wireless or Wired Upper Models XTVFM system receiver</i>	1 Year	Parts & Labor
• Cardio Theater LCD Screen (PVS)	1 Year	Parts & Labor
• Cardio Theater Screen Controllers	1 Year	Parts & Labor
• Quick Change Headphone Jack	90 Day	Parts Only
• Optional DVD Player	1 Year	Parts

Conditions and Restrictions.

This warranty is valid only in accordance with the conditions set forth below:

1. The warranty applies to the Cardio Theater product only while
 - a. it remains in the possession of the original purchaser and proof of purchase is demonstrated,
 - b. it has not been subjected to accident, misuse, abuse, improper service, or mechanical, electrical or non-Precor modification.
 - c. claims are made within the warranty period.
2. This warranty does not cover damage or product failure caused by electrical wiring not in compliance with electrical codes or Precor owner's manual specifications, or failure to provide reasonable and necessary maintenance as outlined in the owner's manual. **This warranty excludes misuse or failures of, for example, poor quality CD's, multiple discs inserted in the player, failures caused by home-produced copies of discs, etc.**
3. Except in Canada, Precor does not pay labor outside the United States.
4. Warranties outside the United States and Canada may vary. Please contact your local Dealer for details.

This Limited Warranty shall not apply to:

1. Software (PROM) version upgrades.
2. Normal wear and tear, consumables and cosmetic items, including, but not limited to the following: labels.
3. Repairs performed on Cardio Theater products missing a serial number or with a serial tag that has been altered or defaced.
4. Service calls to correct installation of the product or instruct owners on how to use the product.
5. Pickup and delivery involved with repairs.
6. Any labor costs incurred beyond the applicable labor warranty period.
7. The user is cautioned that changes or modifications not expressly approved by the manufacturer of the product could void the user's authority to operate the product.

Disclaimer and Release.

The warranties provided herein are the exclusive warranties given by Precor and supersede any prior, contrary or additional representations, whether oral or written. ANY IMPLIED WARRANTIES, INCLUDING THE WARRANTY OF MERCHANTABILITY OR FITNESS FOR A PARTICULAR PURPOSE THAT APPLY TO ANY PARTS DESCRIBED ABOVE ARE LIMITED IN DURATION TO THE PERIODS OF EXPRESS WARRANTIES GIVEN ABOVE FOR THOSE SAME PARTS. PRECOR HEREBY DISCLAIMS AND EXCLUDES THOSE WARRANTIES THEREAFTER. Some States do not allow limitations on how long an implied warranty lasts, so the above limitation may not apply to you. PRECOR ALSO HEREBY DISCLAIMS AND EXCLUDES ALL OTHER OBLIGATIONS OR LIABILITIES, EXPRESS OR IMPLIED, ARISING BY LAW OR OTHERWISE, WITH RESPECT TO ANY NONCONFORMANCE OR DEFECT IN ANY PRODUCT, INCLUDING BUT NOT LIMITED TO: (A) ANY OBLIGATION, LIABILITY, RIGHT, CLAIM OR REMEDY IN TORT, WHETHER OR NOT ARISING FROM THE NEGLIGENCE OF PRECOR OR ITS SUPPLIERS (WHETHER ACTIVE, PASSIVE OR IMPUTED); AND (B) ANY OBLIGATION, LIABILITY, RIGHT, CLAIM OR REMEDY FOR LOSS OF OR DAMAGE TO ANY PRODUCT. This disclaimer and release shall apply even if the express warranty set forth above fails of its essential purpose.

Exclusive Remedies.

For any product described above that fails to conform to its warranty, Precor will provide, at their option, one of the following: (1) repair; (2) replacement; or (3) refund of the purchase price. Limited Warranty service may be obtained by contacting the authorized dealer from whom you purchased the item. Precor compensates Servicicers for warranty trips within their normal service area to repair commercial product at the customer's location. You may be charged a trip charge outside the service area. THESE SHALL BE THE SOLE AND EXCLUSIVE REMEDIES OF THE BUYER FOR ANY BREACH OF WARRANTY.

EXCLUSION OF CONSEQUENTIAL AND INCIDENTAL DAMAGES.

PRECOR AND/OR ITS SUPPLIERS SHALL HAVE NO OBLIGATION OR LIABILITY, WHETHER ARISING IN CONTRACT (INCLUDING WARRANTY), TORT (INCLUDING ACTIVE, PASSIVE, OR IMPUTED NEGLIGENCE AND STRICT LIABILITY), OR OTHERWISE, FOR DAMAGE TO THE PRODUCT, PROPERTY DAMAGE, LOSS OF USE, REVENUE OR PROFIT, COST OF CAPITAL, COST OF SUBSTITUTE PRODUCT, ADDITIONAL COSTS INCURRED BY BUYER (BY WAY OF CORRECTION OR OTHERWISE) OR ANY OTHER INCIDENTAL, SPECIAL, INDIRECT, OR CONSEQUENTIAL DAMAGES, WHETHER RESULTING FROM NONDELIVERY OR FROM THE USE, MISUSE OR INABILITY TO USE THE PRODUCT. This exclusion applies even if the above warranty fails of its essential purposes and regardless of whether such damages are sought for breach of warranty, breach of contract, negligence, or strict liability in tort or under any other legal theory. Some states do not allow the exclusion or limitation of incidental or consequential damages, so the above limitation may not apply to you. This warranty gives you specific legal rights, and you may also have other rights, which vary from state to state.

Complete this portion and keep for your records.

Purchased From: _____
(Dealer or store name)

Phone Number: _____
(Dealer or store telephone number)

Product/Model: _____
(For example: Transmitters, Receivers)

Serial Number: _____
(The serial number is found on the shipping container or item.)

Effective 21 January 2005
P/N CX30037-101

Notes:

Notes:

Notes:



A Division of Precor Incorporated
20031 142nd Ave NE
Woodinville, WA USA 98072-4002

Cardio Theater is a registered trademark, and Cardio Theater PVS and Cardio Theater Quick Change Headphone Jack are trademarks of Precor Incorporated.
www.cardiotheater.com

NOTICE:

Due to continuing advancements in technology, Precor Incorporated reserves the right to make changes in hardware, packaging, and any accompanying documentation without prior written notice.

xTV-8T IMG CX30313-101
Warranty Statement CX30037-101
19 December 2005